

# User Manual

## LV2600

In order to prevent improper operation before use, please carefully read this manual.

# Table of Contents

1. Introduction.....	1
2. Symbols.....	1
3. Safety.....	2
3.1 Handling.....	2
3.2 Installation.....	2
3.3 Response to Emergency Situations.....	2
3.4 Warning Labels.....	3
4. Product Information.....	4
4.1 Battery Module Specifications.....	4
4.2 Battery Charge/discharge.....	5
5. Product Features.....	5
5.1 Battery System Features.....	5
6. Installation.....	7
6.1 Items in the package.....	7
6.2 Clearance.....	8
6.3 Tools.....	8
6.4 Installation Steps.....	9
6.5 System Start up.....	11
7. Commissioning.....	13
8. Exclusion.....	15
9. Troubleshooting and Maintenance.....	15
9.1 Maintenance.....	15
9.2 Troubleshooting.....	15







# 1. Introduction

The document describes the installation, commissioning, maintenance and troubleshooting of the following low voltage battery listed below.  
LV2600

The battery chemistry of this product is Lithium Iron Phosphate. This manual is designed for qualified personnel only. The tasks described in this document should be performed by authorized and qualified technicians only.

After Installation the Installer must explain the user manual to the end user.

# 2. Symbols

	Caution, risk of electric shock.
	Do not place nor install near flammable or explosive materials.
	Install the product out of reach of children.
	Read the instruction manual before starting installation and operation.
	Do not dispose of the product with household wastes.
	Recyclable.
	Disconnect the equipment before carrying out maintenance or repair.
	Observe precautions for handling electrostatic discharge sensitive devices.
	Protective Class 1.
	Caution, risk of electric shock, energy storage timed discharge.

## 3. Safety

Any work on the Batteries should be handled by authorized technicians and hence it is understood that the technicians should familiarize themselves with the contents of this manual before any maintenance or installation is carried out on the system.

### 3.1 Handling

- Do not expose battery to open flame.
- Do not place the product under direct sunlight.
- Do not place the product near flammable materials. It may lead to fire or explosion in case of accident.
- Store in a cool and dry place with ample ventilation.
- Do not store the product near water sources.
- Store the product on a flat surface.
- Store the product out of reach of children and animals.
- Do not damage the unit by dropping, deforming, impacting, cutting or penetrating with a sharp object. It may cause leakage of electrolyte or fire.
- Do not touch any liquid spilled from the product. There is a risk of electric shock or damage to skin.
- Always handle the battery wearing the insulated gloves.
- Do not step on the product or place any foreign objects on it. This can result in damage.
- Do not charge or discharge damaged battery.
- Do not store the battery near water sources.

### 3.2 Installation

- Do not connect the LV2600 to inverter conductors or Photo-Voltaic conductors. This will damage the battery and may result in explosion.
- After unpacking, please check the product for damages and missing parts.
- Make sure that the inverter and battery is completely turned off before commencing installation.
- Do not interchange the positive and negative terminals of the battery.
- Ensure that there is no short circuit of the terminals or with any external device.
- Do not exceed the battery voltage rating of the inverter.
- Do not connect the battery to any incompatible inverter.
- Do not connect different battery types together.
- Please ensure that all the batteries are grounded properly.
- Do not open the battery to repair or disassemble. Only manufacturer is allowed to carry out any such repairs.
- In case of fire, use only dry powder fire extinguisher. Liquid extinguishers should not be used.
- Install the batteries only inside approved manufacturer enclosure. Installing the battery anywhere outside is strictly forbidden.
- Do not install the battery near water sources or places where the battery can get wet.
- Install the battery away from children or pets.
- Do not use battery in high static environment where the protection device might be damaged.
- Do not install with other batteries or cells.

### 3.3 Response to Emergency Situations

The battery can be used in single or multi in parallel. It is designed to prevent hazards or failures. However, manufacturer cannot guarantee their absolute safety.

Under exposure to the internal materials of the battery the following recommendations should be carried out by the user.

- If there has been inhalation, please leave the contaminated area immediately and seek medical attention.
- If there has been contact with eyes, rinse the eyes with running water for 15 minutes and seek medical attention immediately.
- If there has been contact with the skin, wash the contacted area with soap thoroughly and seek medical attention immediately.
- If there has been ingestion, induce vomiting and seek medical attention.

**Fire Situation**

In situations where the battery is on fire, if it is safe to do so, disconnect the battery pack by turning of the switch to shut off the power to the system. Use FM-200 or Co2 fire extinguisher for the battery and an ABC fire extinguisher for the other parts of the system.

Under any fire situation, please evacuate the people from the building immediately before trying to extinguish it.

**Water Situation**

The battery modules are not water resistant. Hence care should be taken not to get it wet. If you find the battery completely or partially submerged in water do not try to open. Contact authorized personnel or manufacturer for further instructions.

**3.4 Warning Labels**

Warning labels are attached on the battery pack.



## Rechargeable Li-ion Battery System

IFpP40/149/96/[16S]M/-20+50/95

Model No.:	LV2600
Rated Capacity:	50Ah
Nominal Energy:	2.56kWh
Nominal Voltage:	51.2Vdc
Voltage range:	43.2-57.6Vdc
Max.charge/ discharge Current:	50A/50A
Ingress Protection:	IP21
Protective Class:	I
Operating Temperature:	-20-55°C
Storage Temperature:	-20-55°C

---



**CAUTION**

-Do not disassemble the battery pack      -Do not short-circuit the battery

-Do not immerse the battery pack in water      -Do not leave the battery near fire

---

Emergency Situations

\* If leaking, fire, wet or damaged, switch off the breaker and go away from the battery.

\* Do not touch the leaking liquid, Do not use water extinguisher. Please use sand or dry powder extinguisher.

---

**Manufacture:** FOXESS CO., LTD.  
Made in China 10-200-20351-00



## 4. Product Information

LV2600 energy storage system is a 48V energy storage system based on lithium-ion ferrous phosphate battery. It is equipped with a customized battery management system (BMS), which is designed for energy storage applications of household photovoltaic power generation users. In the daytime, the surplus power of photovoltaic power generation can be stored in the battery. At night or when necessary, the stored energy can be provided to the electrical equipment, it can improve the use efficiency of photovoltaic power generation, peak-load shifting, and provide emergency standby power.

### 4.1 Battery Module Specifications

Specifications for Battery	
Battery module	LV2600
Nominal capacity (Ah)	50(0.5C, 25±2°C)
Nominal voltage (Vdc)	51.2
Battery voltage range (Vdc)	43.2-57.6
Max. continuous discharging current (A)	50
Max. continuous charging current (A)	50
Recommended charging current (CC-CV) (A)	25
Charging cut off current (constant current and constant voltage) (A)	2.5
Peak charging current (30s) (A)	55
Peak discharging current (30s) (A)	90
Cycle life	≥6000@25°C @90% DOD
Storage temperature	-20°C - 55°C
Operating temperature range	Charge: 0°C - 55°C Discharge: -20°C - 55°C
Discharge capacity (Ah)	0°C±2 @ 1C @ 80% 25°C±2 @ 1C @ 100% 45°C±2 @ 1C @ 96%
Energy density (wh / kg)	88
Ingress protection	IP21
Communication	RS485/CAN
Weight (kg)	28.9
Dimensions (L*W*H) (mm)	440*440*116
Max. operating altitude (m)	2000

Lithiumion Battery Module	
Model No.	LV2600
Nominal capacity	50Ah
Nominal energy	2.56kWh
Nominal voltage	51.2Vdc
Voltage range	43.2-57.6Vdc
Max. charge/discharge current	50A/50A
Ingress protection	IP21
Protective class	I
Operating temperature	- 20°C- 55°C
Storage temperature	- 20°C- 55°C

## 4.2 Battery Charge/Discharge

Current protection			
		trigger	Recover
Battery Charge	First level over current COC	$\geq 55A$ , Lasts 30s	$\geq 60s$ : Recover
	Second level over current COC2	$\geq 60A$ , Lasts 1s	$\geq 60s$ : Recover
Battery Discharge	First level over current DOC	$\geq 55A$ , Lasts 90s	$\geq 60s$ : Recover
	Second level over current DOC2	$\geq 90A$ , Lasts 30s	$\geq 60s$ : Recover
	Third level over current SC	$\geq 150A$ , Lasts 1s	$\geq 60s$ : Recover

# 5. Product Features

## 5.1 Battery System Features

The batteries have been fitted with multiple protection systems to ensure the safe operation of the system. Some of the protection system includes:

- Inverter interface protection: Over voltage, over current, external short circuit, reverse polarity, ground fault, over temp, in rush current.
- Battery Protection: Internal short circuit, over voltage, over current, over temp, under voltage.

The battery system contains the following Interface to allow it to connect and operate efficiently.

### Battery interface:

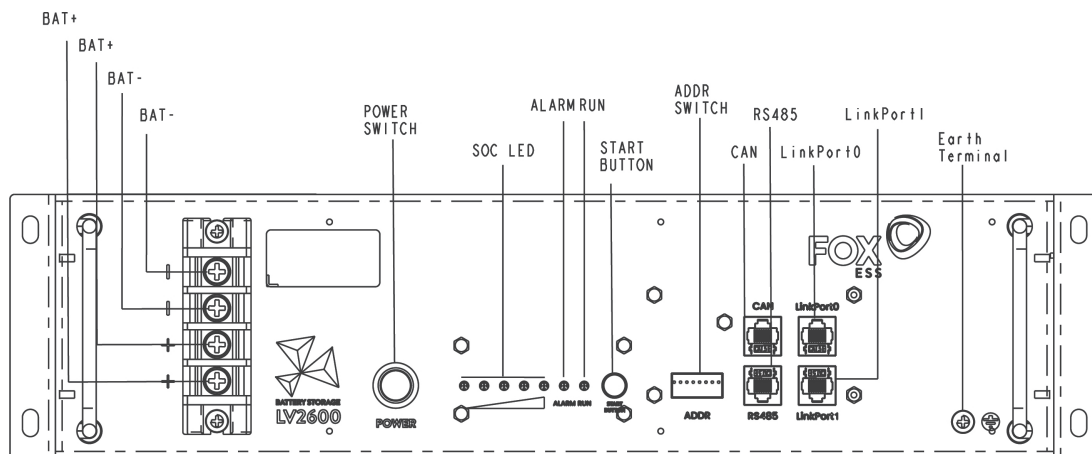

### Running LED

This LED is used to indicate if the battery is operating effectively. A green light on this LED means the battery is ON and operating normally.

### Alarm LED

This LED is used to indicate if the battery is operating failure. A red light on this LED means the battery is operating abnormally.

### Communication parallel interface (Link Port0, Link Port1) and communication interface to inverter (CAN/RS485)

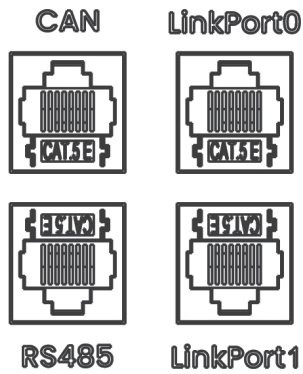

LV2600 has one Linkport 0 and one Linkport 1 for multi-parallel communication using, one for master control and one for slaver.

Network interface description: Link Port0 is connected to the upper battery module, Link Port1 is connected to the lower battery module. CAN / RS485 is the communication interface to the inverter. The interface is defined as follows:

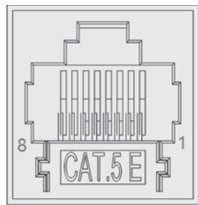

Pin configuration is as follows:

**- Link Port0**

Pin	Function definitions	Cable color	Function declaration
1	B	WHITE&ORANGE	RS485-B
2	A	ORANGE	RS485-A
3	GND	WHITE&GREEN	GND
4	NC	BLUE	NC
5	NC	WHITE&BLUE	NC
6	GND	GREEN	GND
7	A	WHITE&BROWN	RS485-A
8	B	BROWN	RS485-B

**- Link Port1**

Pin	Function definitions	Cable color	Function declaration
1	B	WHITE&ORANGE	RS485-B
2	A	ORANGE	RS485-A
3	GND	WHITE&GREEN	GND
4	NC	BLUE	NC
5	NC	WHITE&BLUE	NC
6	GND	GREEN	GND
7	A	WHITE&BROWN	RS485-A
8	B	BROWN	RS485-B

**- RS485**

Pin	Function definitions	Cable color	Function declaration
1	B	WHITE&ORANGE	RS485-B
2	A	ORANGE	RS485-A
3	GND	WHITE&GREEN	GND
4	NC	BLUE	NC
5	NC	WHITE&BLUE	NC
6	GND	GREEN	GND
7	A	WHITE&BROWN	RS485-A
8	B	BROWN	RS485-B



- CAN

Pin	Function definitions	Cable color	Function declaration
1	NC	WHITE&ORANGE	NC
2	GND	ORANGE	GND
3	NC	WHITE&GREEN	NC
4	CANH	BLUE	CANH
5	CANL	WHITE&BLUE	CANL
6	NC	GREEN	NC
7	NC	WHITE&BROWN	NC
8	NC	BROWN	NC

**Earth Terminal**

This terminal is used to connect the battery to the earth for safety purposes.

**Handle**

The handle is used to carry or move the battery.

**Power Terminal**

A set of positive and negative terminals to connect the battery to the inverter. Tighten the terminal screws.

In addition to the above physical features, the battery has the following performance:

1. 90% Depth of Discharge;
2. Cycle life ≥6000 cycles.

## 6. Installation

### 6.1 Items in the package

Please check if following items are including with the package:



A



B



C



D

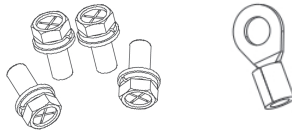

E



F



G



H

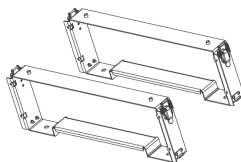

I



J



K



L



M

Object	Description	Object	Description
A	Communication Cable(0.21m)	H	Quick Installation Guide
B	Battery Negative Power Cable(0.26m)	I	Fixing bracket
C	Battery Positive Power Cable(0.26m)	J	Battery-Inverter Communication Cable(1m)
D	Grounding Cable(0.19m)	K	Battery-Inverter Negative Power Cable(1.5m)
E	Mounting screw pack	L	Battery-Inverter Positive Power Cable(1.5m)
F	Earth terminal	M	Battery-Inverter Grounding Cable(1m)
G	User manual		

**Note:**

1. Please use only the components included with the battery pack to ensure proper installation. In the event of a component being damaged or missing, contact your distributor or reseller.
2. Object H, I, J, K and L are provided separately and are not included in the battery package. Please contact your distributor or reseller for availability.

**6.2 Clearance**

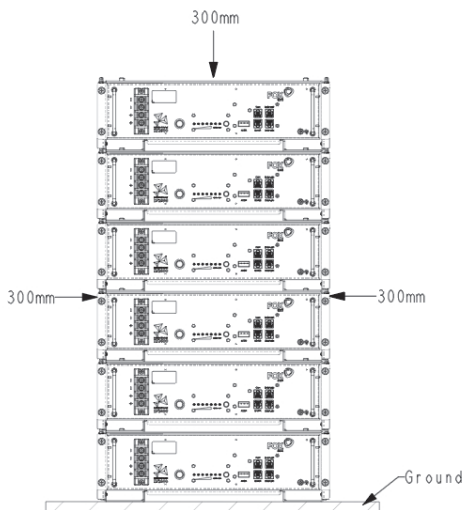

Position	Min size
Left	300mm
Right	300mm
Top	300mm
Bottom	On the ground

Make sure to leave a space of at least 300 mm. A clearance of at least 300 mm must be left around the battery pack for proper cooling.

**Note:** Make sure that the battery pack is always exposed to the ambient air. The battery pack is cooled by natural convection. If the battery pack is entirely or partially covered or shielded, it may cause the battery pack to stop operating.

**6.3 Tools**

The following tools will be required to install the battery.



Screw driver



Crimping modular



Safety shoes



Safety gloves



Safety goggles



Plier



Multimeter



Ribbon

#### 6.4 Installation Steps

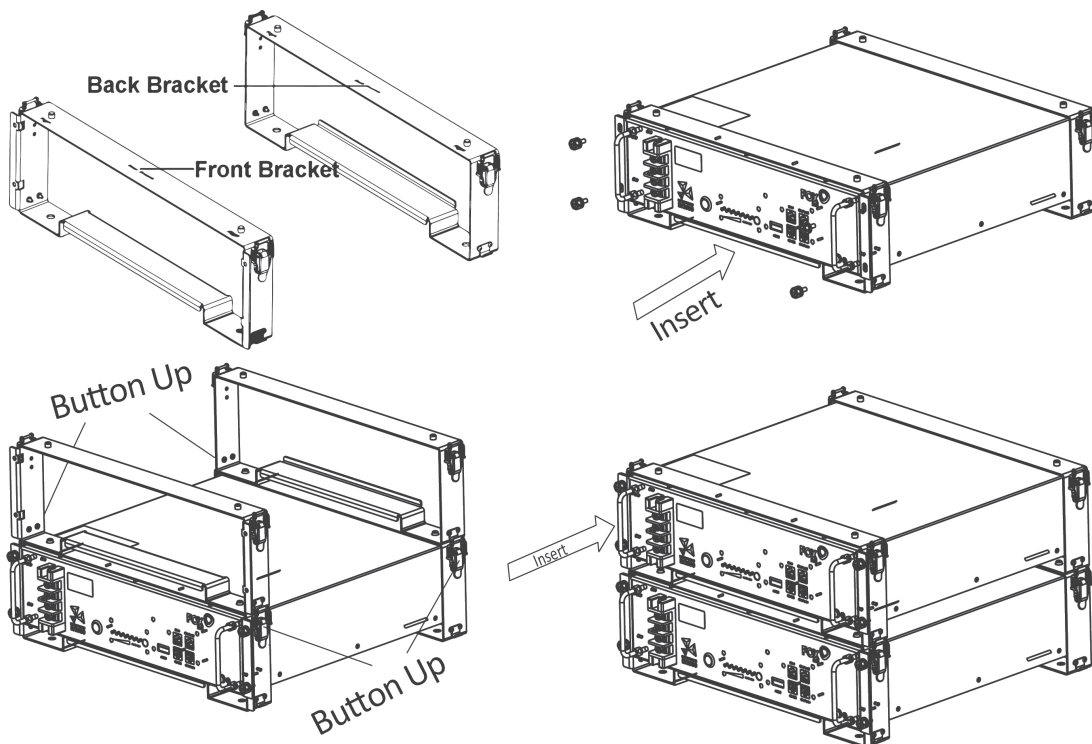

##### STEP-1

Place the front bracket and back bracket as shown above.

##### STEP-2

Insert the battery module into the bracket from front horizontally, and tighten the four screws on the side.

##### STEP-3

Locate the brackets for the second battery on top of the first pair of the bracket and fasten the connecting button on the side.

##### STEP-4

Insert the battery module into the bracket from front horizontally, and tighten the four screws on the side.

**Note:**

Max. 6 pieces battery per stack. If more than 6 pieces, there may be a risk of collapse.

**Battery modules less than 6 pieces:**

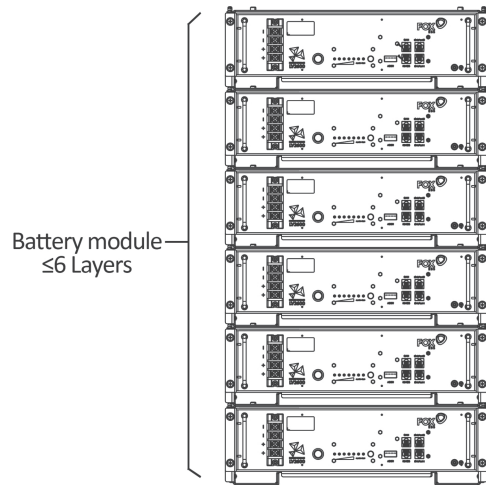

**Battery modules more than 6 pieces:**

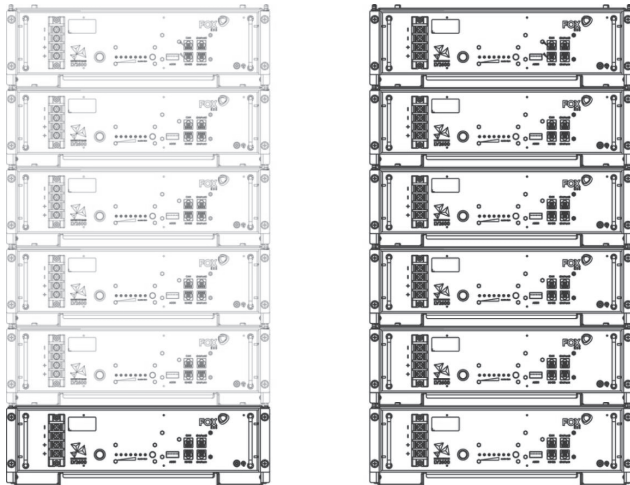

- **Wiring**

Battery power cable:

**STEP-1**

Connect the power cable starting from the first battery module in parallel with other battery modules. Tighten the screws. The positive and negative connection of the battery cable is shown in below.

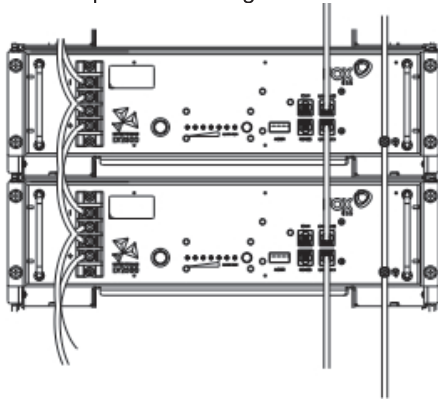

**STEP-2**

Wiring confirmation: Check whether the power wiring is tight and whether the positive and negative polarities are correct. Check if the wiring of the parallel network port is correct.

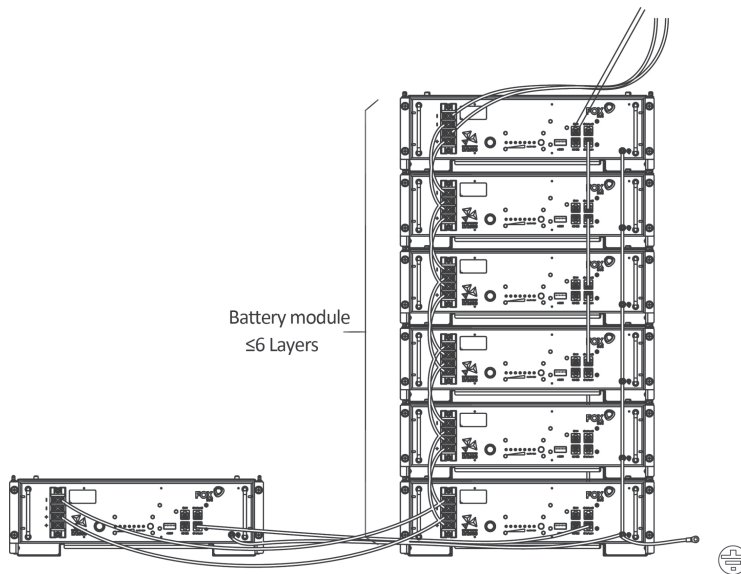

**6.5 System Start up**

- When connected with inverter, the inverter should be turned on first to avoid the current pulse of the inverter increasing to the battery pack.
- All installation and operation must comply with local electrical standards.
- Check all power cables and communication cables carefully.

**1. Turn on the POWER switch**

Dial address selection

Please refer to the parameters in the following table:

**- ADDR**

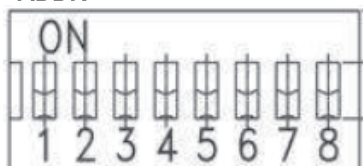

	BAT 1 ADDR (MASTER BAT)	BAT 2 ADDR	BAT 3 ADDR	BAT 4 ADDR	BAT 5 ADDR	BAT 6 ADDR	BAT 7 ADDR	BAT 8 ADDR	BAT 9 ADDR	BAT10 ADDR	BAT11 ADDR	BAT12 ADDR
One Battery	4											
Two Batteries	3	8										
Three Batteries	34	8	7									
Four Batteries	2	8	7	78								
Five Batteries	24	8	7	78	6							
Six Batteries	23	8	7	78	6	68						
Seven Batteries	234	8	7	78	6	68	67					
Eight Batteries	1	8	7	78	6	68	67	678				
Nine Batteries	14	8	7	78	6	68	67	678	5			
Ten Batteries	13	8	7	78	6	68	67	678	5	58		
Eleven Batteries	134	8	7	78	6	68	67	678	5	58	57	
Twelve Batteries	12	8	7	78	6	68	67	678	5	58	57	578

**Note:** "78" indicates that the 7th and 8th Dip switch of the fourth battery pack are "ON", the rest are all "OFF".

- 1) Please change the address switch in the right position accordingly base on the system battery quantity before power on battery.
- 2) After pressing the power switch for 1s, all LEDs will be on and flashing, which indicates that the battery is started normally. After pressing the start button for 3s, the battery will turn on the discharge function.

3) After the communication with the inverter is disconnected for 10s, the battery will turn off the output. If it does not recover after 48 hours, the battery will be shut down.

## 7 Commissioning

There are seven LED indicators on the front of the battery packs to show its operating status.

### - Running LED indication

After start up, the running indicator light flashes, which indicates that the equipment is in normal operation.

### - Alarm LED indication

When the battery is in normal operation, the alarm LED is off, and after the fault occurs, the alarm LED is always on.

### - SOC LED indication

Status	•	Charge	Discharge	Stand by
=100%	•	On	On	Off
	•	On	On	
	•	On	On	
	•	On	On	
	•	On	On	
>100%>SOC>=80%	•	Flash	On	
	•	On	On	
	•	On	On	
	•	On	On	
	•	On	On	
80%>SOC>=60%	•	Off	Off	
	•	Flash	On	
	•	On	On	
	•	On	On	
	•	On	On	
60%>SOC>=40%	•	Off	Off	
	•	Off	Off	
	•	Flash	On	
	•	On	On	
	•	On	On	
40%>SOC>=20%	•	Off	Off	
	•	Off	Off	
	•	Off	Off	
	•	Flash	On	
	•	On	On	
20%>SOC>=0	•	Off	Off	
	•	Off	Off	
	•	Off	Off	
	•	Off	Off	
	•	Flash	On	

**Fault status indicated by indicator:**

- Off
- On
- ◐ Flash

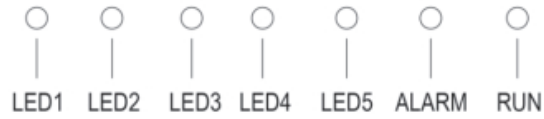

Fault List	LED1	LED2	LED3	LED4	LED5	ALARM	RUN
Adc/afe Fault	◐	●	●	●	●	○	○
High Voltage Fault	●	◐	●	●	●	○	○
Low Voltage Fault	◐	◐	●	●	●	○	○
High Temperature	●	●	◐	●	●	○	○
Low Temperature	◐	●	◐	●	●	○	○
Over current	●	◐	◐	●	●	○	○
Over Voltage/Temperature	◐	◐	◐	●	●	○	○
Leakage Fault	●	●	●	◐	●	○	○
Inverter Comm Fault/ ADDR Fault	◐	●	●	◐	●	○	○
Parallel Comm Fault/ ADDR Fault	●	◐	●	◐	◐	○	○
Precharge Fault	◐	◐	●	◐	◐	○	○
Discharge/Recharge/Prohibit Charging low voltage	●	●	◐	◐	◐	○	○



## 8 Exclusion

The warranty shall not cover the defects caused by normal wear and tear, inadequate maintenance, handling, storage faulty repair, modifications to the battery or pack by a third party other than manufacturer or manufacturer agent, failure to observe the product specification provided herein or improper use or installation, including but not limited to the following.

- Damage during transport or storage.
- Incorrect Installation of battery into pack or maintenance.
- Use of battery or pack in inappropriate environment.
- Improper, inadequate, or incorrect charge, discharge or production circuit other than stipulated herein.
- Incorrect use or inappropriate use.
- Insufficient ventilation.
- Ignoring applicable safety warnings and instructions.
- Altering or attempted repairs by unauthorized personnel.
- In case of force majeure (ex: lightning, storm, flood, fire, earthquake, etc.).
- There are no warranties-implicit or express-other than those stipulated herein. manufacturer shall not be liable for any consequential or indirect damages arising or in connection with the product specification, battery or pack.

## 9 Troubleshooting and Maintenance

### 9.1 Maintenance

- 1) Regularly check whether the service environment of the battery meets the requirements, and the installation position should be far away from the heat source.
- 2) In case of one of the following situations, it needs to be charged in time:
  - The battery is often under charged;
  - The battery has been out of use or stored for more than 3 months.
- 3) Regularly check whether the battery and its supporting terminals, connecting cables and indicator lights are normal.

### 9.2 Troubleshooting

When the red / green LED on the panel is flashing or normally on, it does not mean that the LV2600 is abnormal, it may be just an alarm or protection. Please check the 'LED status indicators' in chapter 7 for the detailed faulty definition before any trouble-shooting steps. In general, the alarm indication is normal without manual intervention. When the alarm triggering state is removed, LV2600 will automatically return to normal use.

#### - Problem determination based on the following points

- 1) Whether the green light on the power switch is on;
- 2) Whether the buzzer in BMS is on;
- 3) Whether the battery system can be communicated with inverter;
- 4) Whether the battery can be output voltage or not.

#### - Preliminary determination steps

- 1) Battery system cannot work, when DC switch on and POWER on, the LED doesn't light up or flash, please consider contact the local distributor.
- 2) The LED display of BMS is normal, but it cannot charge and discharge. Observe the display screen of inverter and there is no SOC. Please check whether the RS485 communication between BMS to inverter is well connected. If the connection is good, please replace a RS485 communication cable. If the SOC is still not visible on the inverter display screen, please contact the local distributor.
- 3) After the battery system is powered on, if you can see the alarm information on the LED and inverter display screen at the same time, please contact the local distributor.

The copyright of this manual belongs to FOXESS CO., LTD. Any corporation or individual should not plagiarize, partially or fully copy (including software, etc.), and no reproduction or distribution of it in any form or by any means is permitted. All rights reserved.

FOXESS CO., LTD

Add: Room A203, Building C, No 205, Binghai Six Road, New Airport Industry Area, Longwan District, Wenzhou, Zhejiang Province.China

Tel: 0510- 68092998

WWW.FOX-ESS.COM